

# PRO 300

Issued May 2008 • Index No. ED/5.21

Engine-Driven Welder/  
AC Generator



## Quick Specs

### Industrial Applications

Pipe Welding  
Structural Steelwork  
Fabrication  
Maintenance  
Repair

### Processes

Stick (SMAW)  
MIG (GMAW)  
Flux Cored (FCAW)  
DC TIG (GTAW)  
Air Carbon Arc (CAC-A)  
Rated: 3/16 in (4.8 mm) carbons,  
Capable: 1/4 in (6.4 mm) carbons  
Air Plasma Cutting and Gouging with  
optional Spectrum models

**Output Range** DC Stick 40–410 A  
DC TIG 20–410 A  
FCAW/MIG 14–40 V

**Generator Output Rated at 104° F (40° C)**  
12,000 Watts Peak  
10,000 Watts Continuous

**Accu-Rated™ – Not Inflated  
Generator Power**

## The Power of Blue.®

**The Professional Welder's Choice** — designed with the professional in mind, the PRO 300 is the best for ease of use, reliability and fuel economy.

### Superior arc performance

- Four preset DIG settings (Stick)
- Hot Start™ (Stick)
- Lift-Arc™ TIG with Auto-Stop™ and Crater-out
- MIG/FCAW arc performance

**Tailored Arc Control (DIG)** allows the arc characteristics to be changed for specific applications and electrodes. Smooth running 7018 or stiffer, more penetrating 6010 electrodes.

**Simple-to-set controls** require no elaborate procedure — just select process and weld!

**Auto Remote Sense (ARS)** detects if a remote control is plugged into the 14-pin receptacle and eliminates confusion of a remote/panel switch.



**The Vault** — ultimate control board reliability. See page 4.

# BUILT TOUGH

**Improved!**  
Superior Arc  
Performance!



**Standard features include:** Stick, Lift-Arc™ TIG, Flux Cored and MIG. Other features include digital preset weld meters, output contactor control, and automatic idle.

**TRUE BLUE**  
3YR. WARRANTY

Welder/generator is warranted by Miller for 3 years, parts and labor.  
Engine is warranted 3 years by engine manufacturer.

Heavy-Duty Low-Speed  
Industrial Engine Choices!



**CATERPILLAR C1.5,**  
21.7 HP @ 1800 RPM  
industrial engine



**Deutz D2008 L04,**  
24.3 HP @ 1800 RPM  
industrial engine

Designed to operate over 10,000 hours before the first basic overhaul. Backed by worldwide support and service.

### Meter maintenance displays.

- Hour meter function
- Oil change interval
- High coolant temperature and low oil pressure shutdowns
- Low fuel shutdown — engine shuts down before system runs out of fuel, making restarts easy.

**Quiet operation:** Improves work site communication.

**Thermal overload protection** prevents machine damage if the duty cycle is exceeded or airflow is blocked.

**Optional Stainless Steel Appearance Package** provides additional exterior protection to withstand corrosive environments.



**Miller Electric Mfg. Co.**  
An Illinois Tool Works Company  
1635 West Spencer Street  
Appleton, WI 54914 USA

**International Headquarters**  
Phone: 920-735-4505  
USA FAX: 920-735-4134  
Canadian FAX: 920-735-4169  
International FAX: 920-735-4125

**Web Site**  
www.MillerWelds.com



**MADE IN USA**  
APPLETON, WI

# Specifications (Subject to change without notice.)



Weld Mode	Weld Output Range	Weld Output Rated at 104° F (40° C)	Max. Open-Circuit Voltage	Generator Power Output Rated at 104° F (40° C)	Sound Levels at Rated Output, 7 m (23 ft)	Dimensions	Net Weight (without fuel)*
CC/DC	20–410 A	400 A, 20 VDC, 30% Duty Cycle 300 A, 32 VDC, 60% Duty Cycle	65	12,000 Watts Peak 10,000 Watts Continuous Single-phase, 120/240 VAC, 83/42 A 60 Hz	<b>CAT:</b> 71 dB (96 Lwa) <b>Deutz:</b> 73 dB (98 Lwa)	H: 32 in (813 mm) W: 26-1/4 in (667 mm) D: 56 in (1422 mm)	<b>CAT:</b> Net: 1128 lb (512 kg) Ship: 1150 lb (522 kg) <b>Deutz:</b> Net: 1208 lb (548 kg) Ship: 1230 lb (558 kg)
CV/DC	14–40 V						

CSA approved. Meets NEMA and IEC output ratings.

\*Additional 82 lb (37 kg) when fuel tank is full.

## Engine Specifications (Engines warranted separately by the engine manufacturer.)

Engine Brand	Features	HP	Type	Engine Speeds	Fuel Capacity	Oil Capacity	Coolant Capacity	Automatic Engine Shutdown
CATERPILLAR C1.5	EPA Tier III indirect-injected liquid-cooled engine. Right side service access with intervals of 250 hrs for oil and filters.	21.7	3-cylinder, industrial liquid-cooled, diesel	1850 RPM weld (1500 RPM idle)	11.5 gal (43.5 L)	6 qt (5.7 L)	6 qt (5.7 L)	Low Oil Pressure, High Coolant Temperature, Low Fuel Level
Deutz D2008 LO4	EPA Tier IVi indirect-injected liquid-cooled engine. Right side service access with intervals of 250 hrs for oil and filters.	24.3	4-cylinder, industrial liquid-cooled, diesel	1800 RPM weld (1500 RPM idle)				

## Performance Data

STICK MODE V/A CURVE – MAX DIG

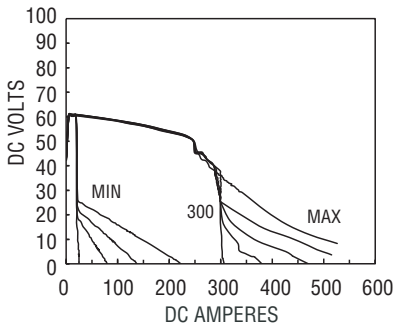

GENERATOR POWER CURVE

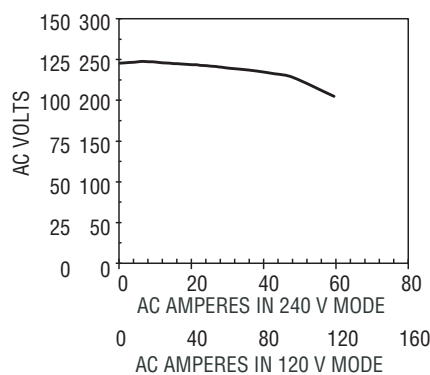

DC TIG MODE V/A CURVE

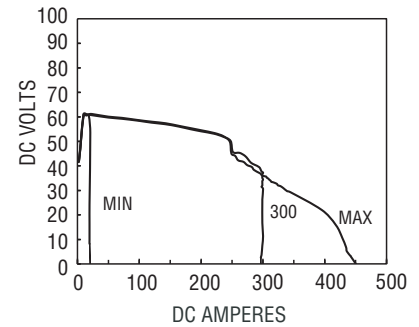

MIG MODE V/A CURVE

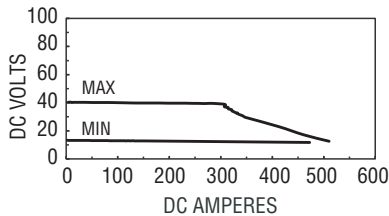

FUEL CONSUMPTION CURVE

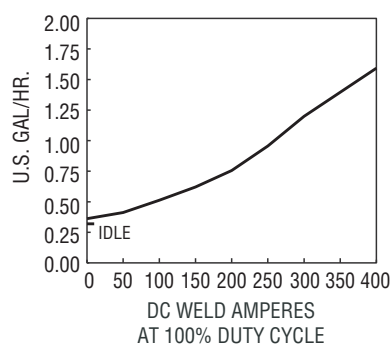

SIMULTANEOUS WELDING AND POWER

Weld Amperes	Total Power Available (Watts)	120 V	240 V
225	3000	25	12.5
175	5000	41.6	20.8
125	5900	49.2	24.6
75	7300	60.8	30.4
25	10,000	83.5	41.7

# Function Guide

1. Self-calibrating digital weld meters with meter maintenance displays.
2. Four Preset DIG Settings offer the best arc characteristics for different electrodes and joint designs. The amount of DIG determines how much amperage (heat) varies with Stick arc length. The combined Process switch along with preset DIG settings make the PRO 300 easy to set without the complication of multiple switches.
3. Hot Start™ provides positive Stick electrode starts making it easy to start all types of electrodes and it also works great for bead tie-ins.
4. Great MIG/FCAW Performance and Arc Starts make the PRO 300's best in its class. Easy to run all wires from .023 in solid wires to large diameter 5/64 in flux cored wires.

5. Lift-Arc™ TIG with Auto-Stop™ and Crater-out (patents pending)

6. Standard 14-Pin Receptacle for simple connection of remote controls and wire feeders. It features Auto Remote Sense™ which automatically switches from Panel to Remote Amperage/Voltage (A/V) control with remote connected. Eliminates confusion of the Panel/Remote A/V switch.
7. Weatherproof Lexan® Nameplate is super durable and resists cracking and fading. Color coding is for ease of operation.

8. Fuel Gauge displays engine hours and oil change interval information. Low Fuel Shutdown shuts engine off prior to running out of fuel to prevent loss of fuel in the system, and make restarts easy. Display will read noFUEL. Turn the machine off, add fuel, and restart.

9. Glow Plugs assist in cold weather starting.

10. Engine Control Switch is used to start the engine and then select between Auto Idle and High Speed Lock.

11. Amperage/Voltage Adjust Control

12. 120 VAC and 240 VAC Receptacles with Circuit Breakers (optional 120 VAC GFCI receptacles available).  
Note: For matching plug, order #119 172.

13. Weld Output Terminals

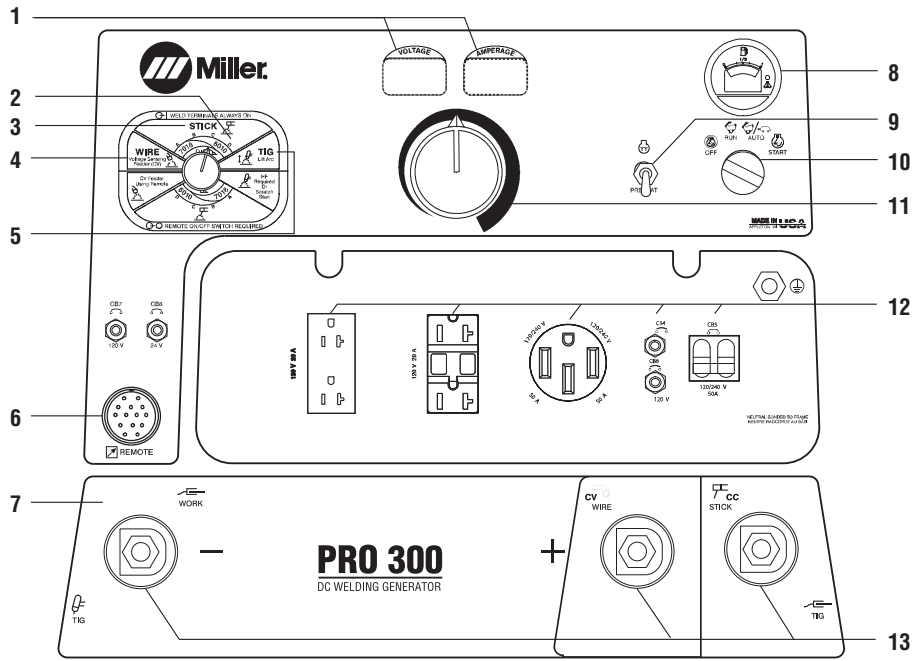

## ARC START with Lift-Arc™

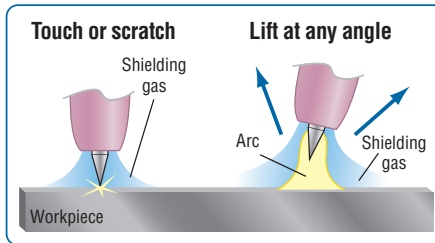

- Reduces or eliminates sticking
- Reduces or eliminates electrode/work contamination
- Low open-circuit voltage (approximately 10 volts)

## ARC END with Auto-Stop™

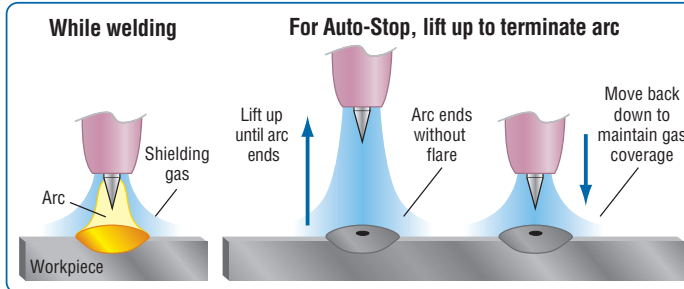

- Eliminates need for a remote control
- Maintains shielding gas coverage
- Eliminates tungsten and workpiece contamination
- Eliminates unwanted arc strikes outside the weld area

## ARC END with Crater-out

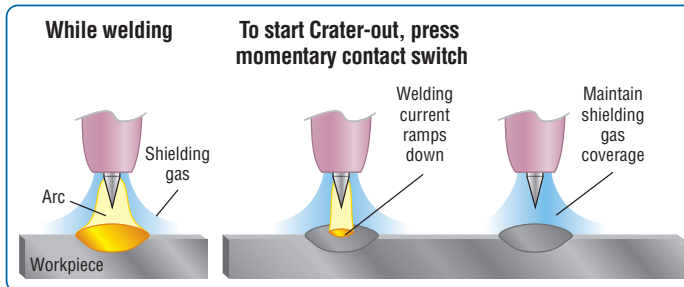

- Maintains shielding gas coverage
- Eliminates tungsten and workpiece contamination
- Crater-out time allows for addition of filler
- Eliminates unwanted arc strikes outside the weld area

# What Makes Miller Industrial Engine Drives So **[TOUGH]**?

## Superior Circuit Board Design

Miller's critical circuit boards are engineered to carry *low power* and *low heat* to reduce thermal stress and minimize expansion and contraction. In contrast, our competitor's boards carry *high power* and *high heat*, making them more vulnerable to failure.



## "The Vault" Makes Upgrading to Miller CC/CV Units Worry-Free

Concerns with circuit board reliability have resulted in some operators steering clear of CC/CV welder/generators — even though they offer a superior arc and multiple welding processes. Miller's circuit board reliability isn't a concern since all PRO 300 and Big Blue multiprocess industrial engine drives feature the Vault.

Created out of two aluminum halves sealed with silicone, as well as watertight harness connections, the Vault provides a clean circuit board environment, protecting the electronics — and controlling output — in heavy industrial applications. No other competitor protects their electronics with a sealed vault, leaving critical circuit boards exposed to harsh elements that can disrupt the machine's electronics, and therefore, its operation.



*"The PRO 300 worked year 'round and never caused any problems. We were amazed at the cold-weather starting. A machine that doesn't run means we have to work overtime... secondly, you don't want to have a crew standing around at \$200 an hour while someone tries to start the machine."*

*Edward McNaughton, Nordcap Steel Docks*

## Rigorous Testing for Tough, Real-World Conditions

To prove our machines go to the limit, Miller industrial engine drives are put to the test in very extreme environmental conditions.

- **Airborne Dust and Sand** — Critical components are exposed to abusive airborne particles in a special testing chamber for weeks, helping make sure they'll operate while facing extreme levels of dirt, dust or sand on the job site.
- **Humidity and Corrosion** — Inside Miller's Houston testing room, critical components are subjected to extended moisture and corrosive salt exposure to ensure they'll run even when exposed to humid climates, corrosive coastal environments, and driving rain.
- **Temperature Extremes** — Miller's industrial engine drives are tested to ensure performance in scorching heat. All Miller engine driven machines are weld rated at 104° F, but actual tests are conducted up to 122° F to assure peak performance.
- **Jobsite/Over-the-Road Abuse** — Miller industrial engine drives are shaken for hours on transportation bed simulators, subjected to severe vibration, and test-dropped and jerked to ensure they'll withstand the stresses that can shut down competitive machines.
- **Continuous Operation** — Miller's industrial engine drives run day and night, in all weather conditions, to assure they'll perform without interruption in the field.



## Why Industrial Engine Drive Customers Choose Miller

The ultimate test of Miller's reliability is how it performs in the field. The quote on the left provide a glimpse of how Miller industrial engine drives perform for customers. Read the full stories, and many others demonstrating Miller's superior reliability, at [MillerWelds.com](http://MillerWelds.com).

# Genuine Miller Accessories



Female Receptacle



**Adapter Cord, Full KVA #300 158** Field  
NEMA 14-50P to NEMA 6-50R. Adapts engine drive 120/240 V plug to common Millermatic® and Spectrum® 240 V plug.



**Full KVA Plug Kit #119 172** Field  
120/240 VAC, 50 amp plug (NEMA 14-50P) to fit full KVA receptacle.

**Cold Weather Starting Aid #195 056** Field  
120 V block heater.

*Note: All models come standard with preheaters (glow plugs).*

**Spark Arrestor (Muffler) Kit #195 291** Field  
Prevents particles from leaving the muffler that could potentially start a fire. Mandatory when operating on California grasslands, brush, or forest-covered land, and all national forests. For other areas, check your state and local laws. Meets U.S. Forest Service Standard 5100-1B.



**FA-1D Lockable Flame Arrestor Fuel Cap #043 947**  
Fuel cap can be padlocked to prevent vandalism. A built-in flame arrestor prevents flames or sparks from entering the fuel tank.

**Protective Cover #195 301** Field  
Blue water-resistant cover with Miller logo resists stains and mildew, and protects the finish of your welder.

## Stick (SMAW) Welding

### Weld Leads

- #173 851** 2/0, 350 A, 100% duty cycle, 50 ft stinger, 50 ft work cable
- #043 952** 2/0, 300 A, 100% duty cycle, 100 ft stinger, 50 ft work cable

## Plasma Cutting



**Spectrum® 375 X-TREME™ #907 303**  
**Spectrum® 375 X-TREME™ with X-CASE™ #907 339** (not shown)  
See Lit. Index No. PC/9.2.

**Spectrum® 625 #907 058**  
See Lit. Index No. PC/9.5.

**Spectrum 2050 #903 777-01-2**  
See Lit. Index No. PC/7.0.

## MIG (GMAW) or Flux Cored (FCAW)



**Millermatic® Passport® Plus #907 401**  
Portable, all-in-one MIG package features ultimate arc performance, self-contained gas bottle,

and flexibility to plug into 115 or 230 V power with Miller exclusive Multi-Voltage Plug. See Lit. Index No. DC/12.53.



**SuitCase™ X-TREME™ 8VS Wire Feeder #300 093**  
**SuitCase™ X-TREME™ 12VS Wire Feeder #195 500**

Lightweight, voltage-sensing wire feeders include secondary contactor and gas valve. Require drive roll kit. See Lit. Index No. M/6.41.



**SuitCase™ 8RC Wire Feeder #194 938**  
**SuitCase™ 12RC Wire Feeder #194 940**  
Lightweight and flexible enough to run a variety of wires up to .062 in diameter. Comes standard with remote voltage control. See Lit. Index No. M/6.5.

**MIG (GMAW)/Flux Cored (FCAW) Guns**  
Miller produces a complete line of dependable MIG guns. See Lit. Index Nos. AY/15.0, AY/16.0 and AY/17.0.



**Spoolmatic® 30A Spool Gun #130 831**  
Air-cooled, 200-amp, 1-lb spool gun for aluminum MIG. See Lit. Index No. M/1.73.

**WC-24 Control #137 549**  
Use with Spoolmatic 30A.

**XR™ Wire Feeders and Guns**  
Push-pull system designed to handle difficult-to-feed soft alloy wires such as aluminum. See Lit. Index No. M/1.7, M/1.71, and M/1.73.

## TIG (GTAW) Welding



**HF-251 Series #042 388**  
**HF-251D-1, 115 VAC**  
High-frequency arc starter and stabilizer. See Accessory Lit. Index No. AY/5.0.

## Multiple Operator Welding

*The XMT 304, CST 280 and Dynasty 200 power sources can be run off the machine's generator to provide two arcs with only one engine. There is no arc interaction under 180 amps.*



**XMT® 304 #903 471 and #903 471-01-1 only**  
See Lit. Index No. DC/18.8.



**CST™ 280 #907 244, #907 244-01-1 #907 251, #907 251-01-1**  
See Lit. Index No. DC/29.55.



**Dynasty® 200 Series #907 099 #907 099-01-1**  
See Lit. Index No. AY/4.8.

## Genuine Miller Accessories (continued)

### Remote Controls



#### RHC-14 Hand Control #129 340

Miniature hand control for remote current and contactor control. Dimensions: 4 x 4 x

3-1/4 in (102 x 102 x 82 mm). Includes 20 ft (6 m) cord and 14-pin plug.



#### RFCS-14 HD Foot Control #194 744

Heavy-duty foot current and contactor control. Includes 20 ft (6 m) cord and 14-pin plug.



**RMLS-14 #129 337** 14-pin plug Momentary- and maintained-contact rocker switch for contactor control. Push forward for maintained contact and back for momentary contact. Includes 20 ft (6 m) cord.



**RMS-14 On/Off Control #187 208** Momentary-contact switch for contactor control. Rubber-covered pushbutton dome switch ideal for repetitive on-off applications. Includes 26.5 ft (8 m) cord and 14-pin plug.



**RCC-14 Remote Contactor and Current Control #151 086** 14-pin plug Rotary-motion fingertip control fastens to TIG torch using two Velcro® straps. Includes 28 ft (8.5 m) control cord.



#### PRHC-14 Hand Control #195 511

Complete current or voltage control brings 120 volts GFCI power to work area in a single cord.

Housed in a durable light aluminum case and includes 125 ft (38 m) cord with plugs.

#### Extension Cords for 14-Pin Remote Controls or 24 VAC Wire Feeders

#122 973 25 ft (7.6 m)

#122 974 50 ft (15.2 m)

#122 975 75 ft (23 m)

## Trailers and Hitches (Note: Trailers are shipped unassembled.)



Shown with ball hitch, fenders and lights.

#### Mid-Frame Trailer #195 481

1500 lb (680 kg) capacity highway trailer. Welded steel tubing frame, heavy-duty axle with roller bearing hubs and leaf-spring suspension. Comes with jack stand, and safety chain (order hitch separately).

#### Ball Hitch, 2 in #195 493

#### Lunette Eye 2-1/2 in (64 mm) #043 824

#### Fender Kit #195 482

#### Light Kit #195 483

Requires fender kit.

#### Cable Tree #195 023

Provides an area to conveniently wrap weld cables and extension cords.



#### HWY-224 Trailer

#043 805 For highway use.

#### OFR-224 Trailer

#043 802 For off-road use.

A 2650 lb (1202 kg) capacity trailer. Welded steel tubing frame, heavy-duty axle with roller bearing hubs and leaf-spring suspension. Includes jack stand, 2 in (50 mm) ball hitch. *HWY-224 also includes fenders and lights.*

*Note: Trailer is shipped unassembled.*

#### Cable Tree #043 826

Provides an area to conveniently wrap weld cables and extension cords.

#### Lunette Eye 2-1/2 in (64 mm) #043 824

### Mounting Specifications

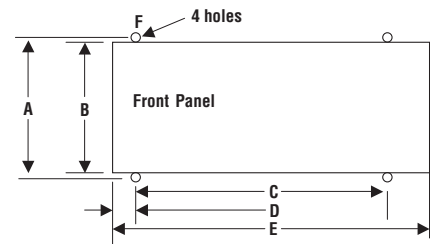

A. 27-3/4 in (705 mm)

B. 26-1/4 in (667 mm)

C. 52 in (1321 mm)

D. 2 in (51 mm)

E. 56 in (1422 mm)

F. 9/16 in (14 mm) dia.

**Height:** 32 in (813 mm)

**Width:** 26-1/4 in (667 mm)

**Depth:** 56 in (1422 mm)

## Specifications (Subject to change without notice.)

Model	Gross Axle Weight Rating	Gross Vehicle Weight Rating	Net Payload	Height of Bed	Road Clearance	Track (Center to center of tires)	Standard Tires (Standard rating or P-size rating)	Dimensions	Net Weight
Mid-Frame	1500 lb (680 kg)	1666 lb (755 kg)	1424 lb (645 kg)	18-1/2 in (470 mm)	6-1/2 in (165 mm)	45 in (1143 mm)	B78-13	Length: 98 in (2489 mm) Width: 52 in (1321 mm)*	242 lb (110 kg)
HWY-224 OFR-224	3500 lb (1588 kg)	2960 lb (1343 kg)	2650 lb (1202 kg)	18-1/2 in (470 mm)	7-1/2 in (191 mm)	52 in (1321 mm)	B78-13	Length: 122-1/2 in (3112 mm) Width: HWY-61 in (1549 mm)* OFR-58-1/2 in (1486 mm)	355 lb (161 kg)

\* Width at outside of fenders.

# Typical Installations



## Stick (SMAW) Basic Equipment

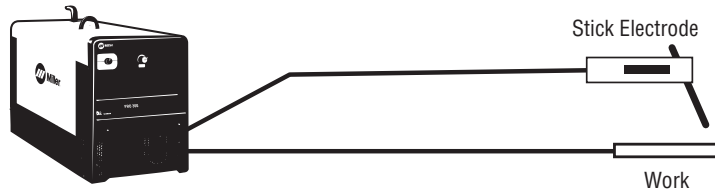

## Flux-Cored (FCAW) Basic Equipment

SuitCase™ X-TREME™ 8VS #300 093  
 SuitCase™ X-TREME™ 12VS #195 500

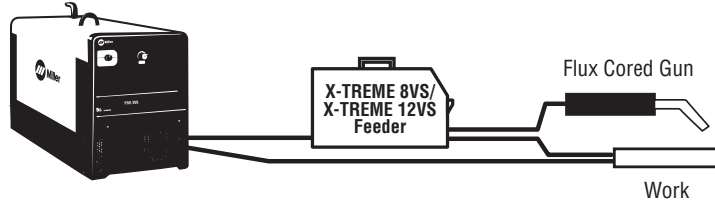

## MIG (GMAW) Basic Equipment

SuitCase™ 8RC #194 938  
 SuitCase™ 12RC #194 940

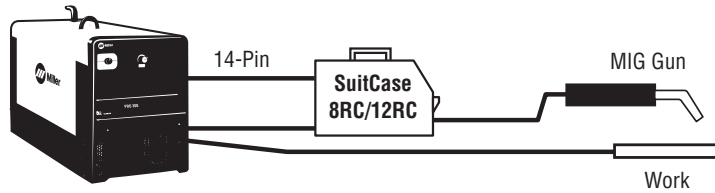

## Aluminum MIG (GMAW) Basic Equipment

Spoolmatic® 30A #130 831  
 WC-24 #137 549

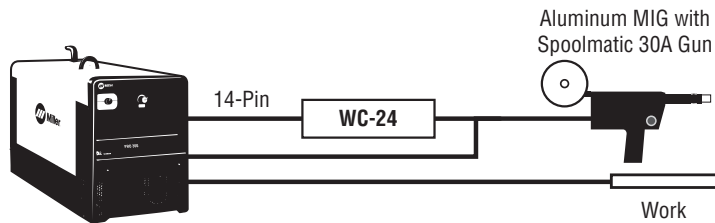

## TIG (GTAW) Basic Equipment

Dynasty® 200 Series  
 HF-251D-1 #042 388\*  
 \*TIG power cable adapter required

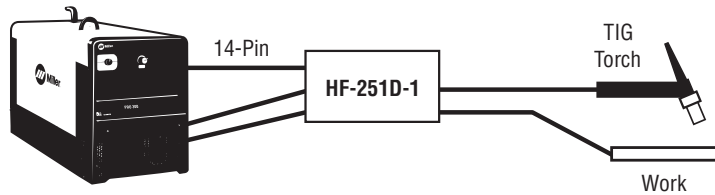

## Plasma Basic Equipment

Spectrum® 375 X-TREME™ #907 303  
 Spectrum® 375 X-TREME™ with X-CASE™ #907 339  
 Spectrum® 625 #907 058  
 Spectrum® 2050 #903 777-01-2

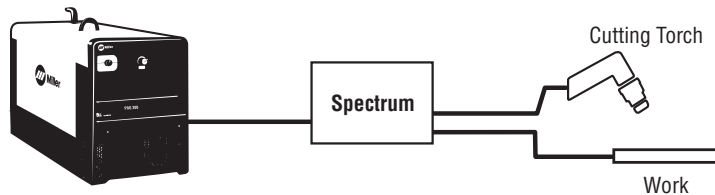

# Ordering Information

Equipment and Options	Stock No.	Description	Qty.	Price
<b>PRO 300 CC/CV</b>	#907 144 #907 144-01-1 #907 144-02-1	CAT CC/CV CAT CC/CV, 120 V Block Heater CAT CC/CV, 120 V Block Heater, Stainless Steel Package		
<b>PRO 300 D CC/CV</b>	#907 399 #907 399-01-1 #907 399-02-1	Deutz CC/CV Deutz CC/CV, 120 V Block Heater Deutz CC/CV, 120 V Block Heater, Stainless Steel Package		
<b>Accessories</b>				
Cold Weather Starting Aid	#195 056	Field, 120 V block heater		
Spark Arrestor (Muffler) Kit	#195 291	Field		
FA-1D Lockable Flame Arrestor Fuel Cap	#043 947	Field		
Adapter Cord, Full KVA	#300 158	Field		
Full KVA Plug	#119 172	Field		
Protective Cover	#195 301	Field		
<b>Remote Controls and Switches</b>		See page 6		
<b>Multiple Operator Welding</b>				
XMT® 304 CC/CV	#903 471 #903 471-01-1	See Lit Index No. DC/18.8		
GST™ 280 CC/DC	#907 244 #907 244-01-1 #907 251 #907 251-01-1	220-230/460–575 VAC w/Dinse-style connectors. See Lit Index No. DC/29.55 220-230/460–575 VAC w/Tweco-style connectors. See Lit Index No. DC/29.55 208-230/400–460 VAC w/Dinse-style connectors. See Lit Index No. DC/29.55 208-230/400–460 VAC w/Tweco-style connectors. See Lit Index No. DC/29.55		
Dynasty® 200 SD	#907 099	Basic controls for AC/DC TIG/Stick, 120–460 VAC. See Lit Index No. AY/4.8		
Dynasty® 200 DX	#907 099-01-1	Full feature controls for AC/DC TIG/Stick, 120–460 VAC. See Lit Index No. AY/4.8		
<b>Plasma Cutting</b>				
Spectrum® 375 X-TREME™ (only)	#907 303	See Lit Index No. PC/9.2		
Spectrum® 375 X-TREME™ with X-CASE™	#907 339	See Lit Index No. PC/9.2		
Spectrum® 625	#907 058	See Lit Index No. PC/9.5		
Spectrum® 2050	#903 777-01-2	See Lit Index No. PC/7.0		
<b>MIG/Flux Cored Welding</b>				
Millermatic® Passport® Plus	#907 401	Includes gas bottle and MVP. See Lit. Index No. DC/12.53		
SuitCase™ X-TREME™ 8VS	#300 093	See Lit Index No. M/6.41		
SuitCase™ X-TREME™ 12VS	#195 500	See Lit Index No. M/6.41		
SuitCase™ 8RC	#194 938	See Lit Index No. M/6.5		
SuitCase™ 12RC	#194 940	See Lit Index No. M/6.5		
MIG (GMAW) and Flux Cored (FCAW) Guns		See Lit Index Nos. AY/15.0, AY/16.0 and AY/17.0		
Spoolmatic® 30A Spool Gun	#130 831	Requires WC-24 Control. See Lit. Index No. M/1.73		
WC-24 Control	#137 549	See Lit. Index No. M/1.5		
XR™ Wire Feeder Control and Guns		See Lit. Index No. M/1.7, M/1.71, and M/1.73		
<b>TIG Welding</b>				
HF-251 Series	#042 388	115 VAC. See Lit. Index No. AY/5.0		
<b>Trailers and Hitches</b>				
Mid-Frame Trailer	#195 481	Trailer with jack stand and safety chain. Order hitch separately		
Ball Hitch, 2 in	#195 493			
Lunette Eye	#043 824			
Fender Kit	#195 482			
Light Kit	#195 483	Requires fender kit		
Cable Tree	#195 023	Trailer-mounted cable holder		
HWY-224 Trailer	#043 805	Trailer with lights, fenders and 2 in ball hitch. For highway use		
OFR-224 Trailer	#043 802	Trailer with 2 in ball hitch. For off-road use		
Lunette Eye, 2-1/2 in	#043 824	For HWY-224 or OFR-224		
Cable Tree	#043 826	Trailer-mounted cable holder for HWY-224 or OFR-224		

Date: \_\_\_\_\_ Total Quoted Price: \_\_\_\_\_

Distributed by:

